

PHYSICS
SCIENCE Paper – 1
(One hour and a half)

Answers to this Paper must be written on the paper provided separately.

*You will **not** be allowed to write during the first 15 minutes.*

This time is to be spent in reading the Question Paper.

The time given at the head of this Paper is the time allowed for writing the answers.

Section I is compulsory. Attempt any four questions from Section II.

The intended marks for questions or parts of questions are given in brackets [].

SECTION I (40 Marks)

*Attempt **all** questions from this Section.*

Question 1

- (a) (i) Define one newton.
(ii) Write the relation between S.I. unit and C.G.S unit of force. [2]
- (b) Where does the position of centre of gravity lie for
(i) a circular lamina
(ii) a triangular lamina? [2]
- (c) A man can open a nut by applying a force of 150 N by using a lever handle of length 0.4 m. What should be the length of the handle if he is able to open it by applying a force of 60 N? [2]
- (d) Name a machine which can be used to
(i) multiply force
(ii) change the direction of force applied. [2]
- (e) The diagram below shows a lever in use.

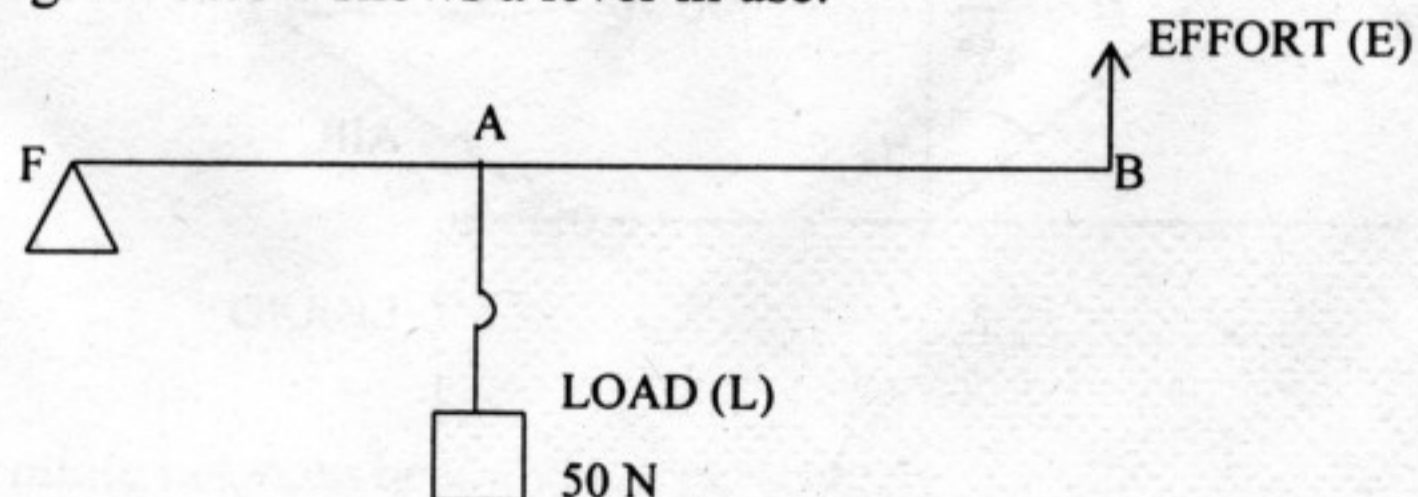

- (i) To which class of lever does it belong?

This Paper consists of 7 printed pages and 1 blank page.

- (ii) If $FA = 40 \text{ cm}$, $AB = 60 \text{ cm}$, then find the mechanical advantage of the lever. [2]

Question 2

- (a) A ball of mass 200 g falls from a height of 5 m . What will be its kinetic energy when it just reaches the ground? ($g = 9.8 \text{ m s}^{-2}$) [2]
- (b) In the diagram below, PQ is a ray of light incident on a rectangular glass block.
- (i) Copy the diagram and complete the path of the ray of light through the glass block. In your diagram, mark the angle of incidence by letter 'i' and the angle of emergence by the letter 'e'.
- (ii) How are the angles 'i' and 'e' related to each other?

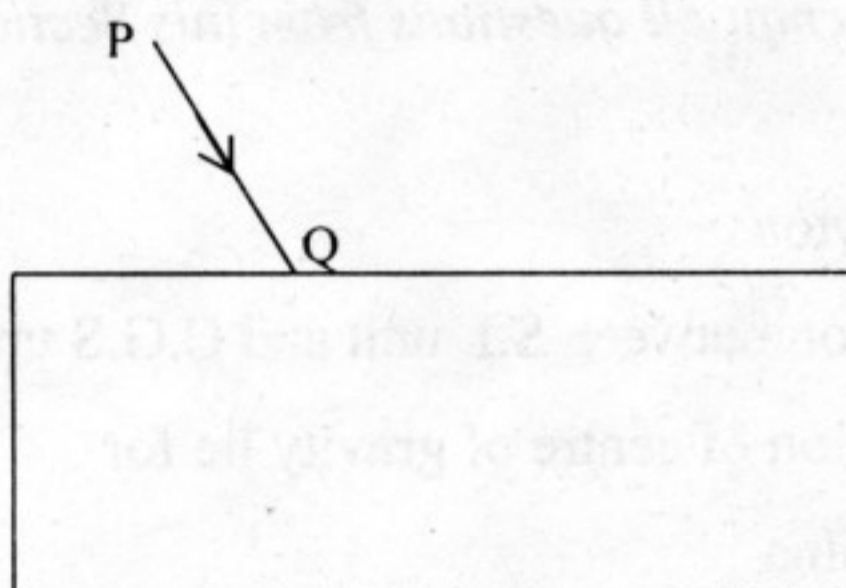

[2]

- (c) A ray of monochromatic light enters a liquid from air as shown in the diagram given below.
- (i) Copy the diagram and show in the diagram the path of the ray of light after it strikes the mirror and re-enters the medium of air.
- (ii) Mark in your diagram the two angles on the surface of separation when the ray of light moves out from the liquid to air. [2]

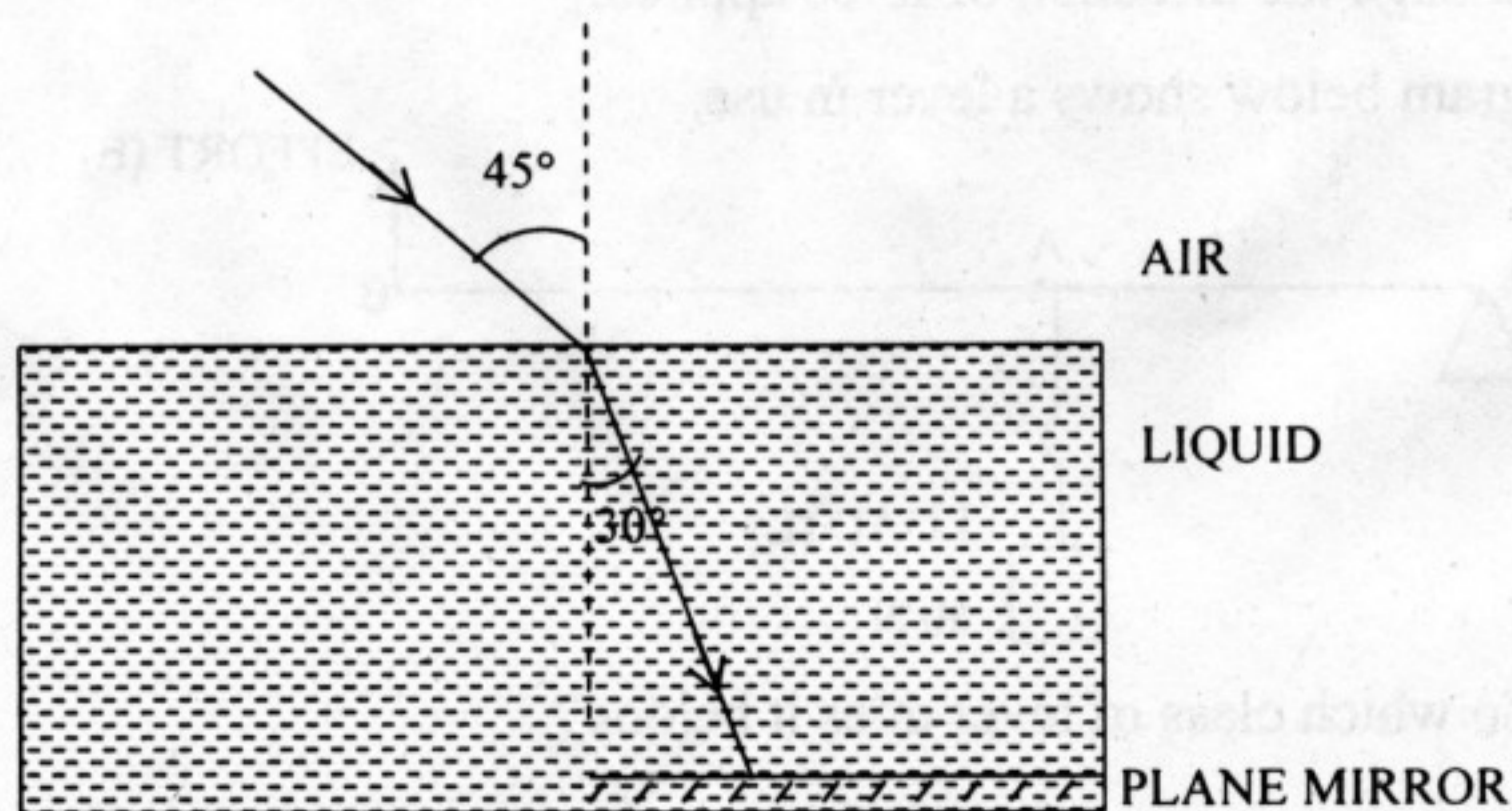

- (d) (i) When does a ray of light falling on a lens pass through it undeviated?
(ii) Which lens can produce a real and inverted image of an object? [2]
- (e) (i) How is the refractive index of a medium related to its real depth and apparent depth?
(ii) Which characteristic property of light is responsible for the blue colour of the sky? [2]

Question 3

- (a) When acoustic resonance takes place, a loud sound is heard. Why does this happen? Explain. [2]
- (b) (i) Three musical instruments give out notes at the frequencies listed below. Flute: 400 Hz; Guitar: 200 Hz; Trumpet: 500 Hz. Which one of these has the highest pitch?
(ii) With which of the following frequencies does a tuning fork of 256 Hz resonate? 288 Hz, 314 Hz, 333 Hz, 512 Hz. [2]
- (c) Two bulbs are marked 100 W, 220 V and 60 W, 110 V. Calculate the ratio of their resistances. [2]
- (d) (i) What is the colour code for the insulation on the earth wire?
(ii) Write an expression for calculating electrical power in terms of current and resistance. [2]
- (e) Calculate the equivalent resistance between A and B from the following diagram: [2]

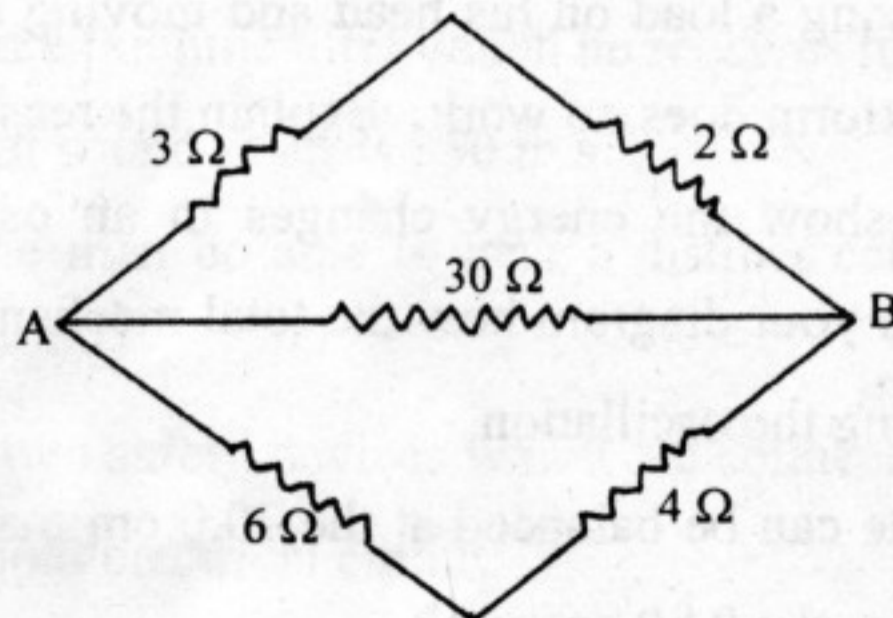

Question 4

- (a) Differentiate between heat and temperature. [2]
- (b) (i) Define Calorimetry.

- (ii) What is meant by Energy degradation? [2]
- (c) 200 g of hot water at 80 °C is added to 300 g of cold water at 10 °C. Calculate the final temperature of the mixture of water. Consider the heat taken by the container to be negligible. [specific heat capacity of water is 4200 J kg⁻¹ °C⁻¹] [2]
- (d) Fill in the blanks in the following sentences with appropriate words:
- (i) During the emission of a beta particle, the _____ number remains the same.
- (ii) The minimum amount of energy required to emit an electron from a metal surface is called _____ . [2]
- (e) A mixture of radioactive substances gives off three types of radiations.
- (i) Name the radiation which travels with the speed of light.
- (ii) Name the radiation which has the highest ionizing power. [2]

SECTION II (40 Marks)

Attempt any four questions from this Section

Question 5

- (a) (i) What is meant by an ideal machine?
- (ii) Write a relationship between the mechanical advantage (M.A.) and velocity ratio (V.R.) of an ideal machine.
- (iii) A coolie carrying a load on his head and moving on a frictionless horizontal platform does no work. Explain the reason why. [3]
- (b) Draw a diagram to show the energy changes in an oscillating simple pendulum. Indicate in your diagram how the total mechanical energy in it remains constant during the oscillation. [3]
- (c) A uniform metre scale can be balanced at the 70.0 cm mark when a mass of 0.05 kg is hung from the 94.0 cm mark.
- (i) Draw a diagram of the arrangement.
- (ii) Find the mass of the metre scale. [4]

Question 6

- (a) (i) State the laws of refraction of light.
- (ii) Write a relation between the angle of incidence (i), angle of emergence (e), angle of prism (A) and angle of deviation (d) for a ray of light passing through an equilateral prism. [3]
- (b) (i) Suggest one way, in each case, by which we can detect the presence of:
- (1) Infrared radiations
- (2) Ultraviolet radiations.
- (ii) Give one use of Infrared radiations. [3]
- (c) An object is placed in front of a lens between its optical centre and the focus and forms a virtual, erect and diminished image.
- (i) Name the lens which formed this image.
- (ii) Draw a ray diagram to show the formation of the image with the above stated characteristics. [4]

Question 7

- (a) (i) Name the type of waves which are used for sound ranging.
- (ii) Why are these waves mentioned in (i) above, not audible to us?
- (iii) Give one use of sound ranging. [3]
- (b) A man standing 25 m away from a wall produces a sound and receives the reflected sound.
- (i) Calculate the time after which he receives the reflected sound if the speed of sound in air is 350 m s^{-1} .
- (ii) Will the man be able to hear a distinct echo? Give a reason for your answer. [3]
- (c) (i) Name two safety devices which are connected to the live wire of a household electrical circuit.
- (ii) Give one important function of each of these two devices. [4]

Question 8

- (a) (i) Draw a graph of Potential difference (V) *versus* Current (I) for an ohmic resistor.
- (ii) How can you find the resistance of the resistor from this graph?
- (iii) What is a non-ohmic resistor? [3]
- (b) (i) An electric bulb is marked 100 W, 250 V. What information does this convey?
- (ii) How much current will the bulb draw if connected to a 250 V supply? [3]
- (c) Three resistors are connected to a 12 V battery as shown in the figure given below:

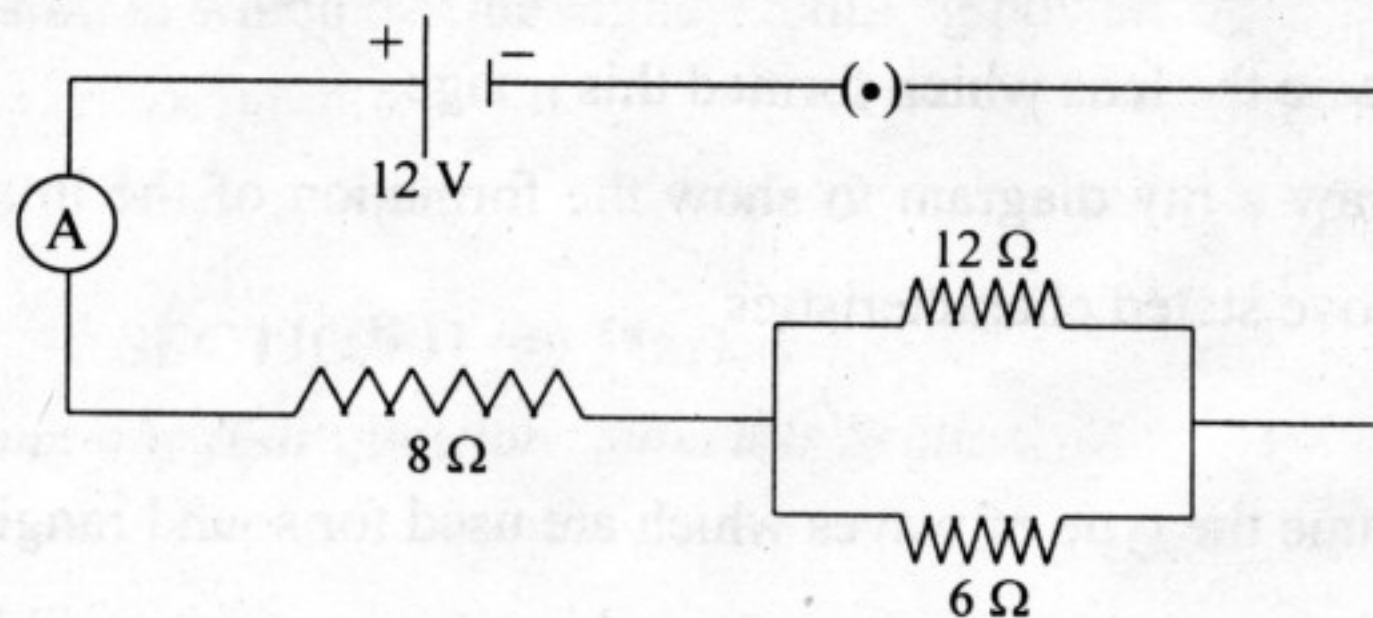

- (i) What is the current through the 8 ohm resistor?
- (ii) What is the potential difference across the parallel combination of 6 ohm and 12 ohm resistor?
- (iii) What is the current through the 6 ohm resistor? [4]

Question 9

- (a) (i) Explain why the weather becomes very cold after a hail storm.
- (ii) What happens to the heat supplied to a substance when the heat supplied causes no change in the temperature of the substance? [3]
- (b) (i) When 1 g of ice at 0 °C melts to form 1 g of water at 0 °C then, is the latent heat absorbed by the ice or given out by it?

- (ii) Give one example where high specific heat capacity of water is used as a heat reservoir.
- (iii) Give one example where high specific heat capacity of water is used for cooling purposes. [3]
- (c) 250 g of water at 30 °C is present in a copper vessel of mass 50 g. Calculate the mass of ice required to bring down the temperature of the vessel and its contents to 5 °C.
- Specific latent heat of fusion of ice = $336 \times 10^3 \text{ J kg}^{-1}$
- Specific heat capacity of copper vessel = $400 \text{ J kg}^{-1} \text{ }^\circ\text{C}^{-1}$
- Specific heat capacity of water = $4200 \text{ J kg}^{-1} \text{ }^\circ\text{C}^{-1}$. [4]

Question 10

- (a) (i) State two properties which a substance should possess when used as a thermionic emitter.
- (ii) When an alpha particle gains two electrons it becomes neutral and becomes an atom of an element which is a rare gas. What is the name of this rare gas? [3]
- (b) (i) Define radioactivity.
- (ii) What happens inside the nucleus that causes the emission of beta particle?
- (iii) Express the above change in the form of an equation. [3]
- (c) (i) Name a device which is commonly used to convert an electrical signal into a visual signal.
- (ii) The nucleus ${}_{84}^{202}\text{X}$ emits an alpha particle and forms the nucleus Y. Represent this change in the form of an equation.
- (iii) What changes will take place in the mass number and atomic number of the nucleus Y if it emits gamma radiations? [4]